

SWIT®

SWIT Electronics Co., Ltd.

Model: S-1053F

5.5" Full HD Broadcast LCD Monitor

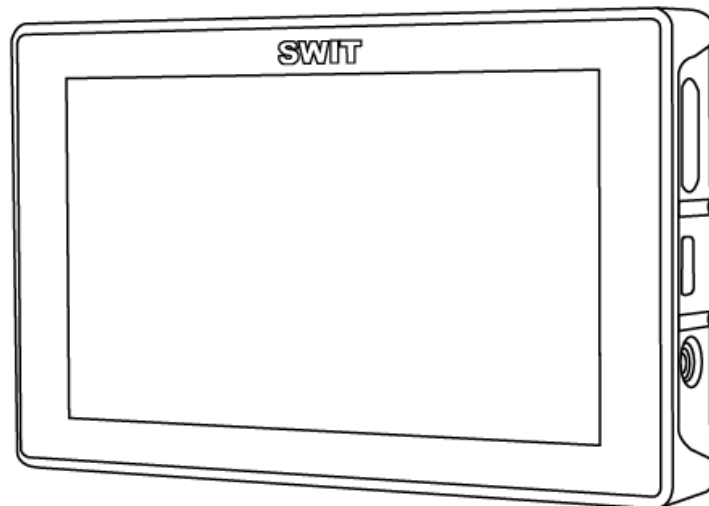

User Manual

Ver: C

Please read this User Manual
throughout before using.

Preface

1. All internal technologies of this product are protected, including device, software and trademark. Reproduction in whole or in part without written permission is prohibited.
2. All brands and trademarks of SWIT Electronics Co., Ltd. are protected and other relative trademarks in this user manual are the property of their respective owners.
3. Due to constant effort of product development, SWIT reserves the right to make changes and improvements to the product described in this manual without prior notice
4. The warranty period of this product is 2 years, and does not cover the following:
 - (1) Physical damage to the surface of the products, including scratches, cracks or other damage to the LCD screen or other externally exposed parts;
 - (2) The LCD dot defects are not over three;
 - (3) Any damage caused by using third-party power adaptors;
 - (4) Any damage or breakdown caused by use, maintenance or storage not according to the user manual
 - (5) The product is disassembled by anyone other than an authorized service center;
 - (6) Any damage or breakdown not caused by the product design, workmanship, or manufacturing quality, etc.

* Any sales personnel have no rights to provide additional warranty.
5. For any suggestions and requirements on this product, please contact us through phone, fax, Email, etc.

SWIT Electronics Co., Ltd.

Address: 10 Hengtong Road, Nanjing Economic and Technological Development Zone,
Nanjing 210038, P.R.China

Phone: +86-25-85805753

Fax: +86-25-85805296

Email: contact@swit.cc

Website: <http://www.swit.cc>

<http://www.swit.cc>

Maintenance

Warning

1. In order to reduce the risk of fire and electrical shock, do not lay this product in rain or damp places.
2. Please keep away from the strong magnetic field; it may cause the noise of the video and audio signals.

The power

1. Please use the power adapter provided or recommended by the manufacturer in order to avoid damage.
2. For a third party power adapter, please make sure the voltage range, supplied power, and polarity of power lead are fit.
3. Please disconnect the power cable under the following situations:
 - (A) .If you do not operate this monitor for a period of time.
 - (B) .If the power cable or power adaptor is damaged.
 - (C) .If the monitor housing is broken.

The monitor

1. Please don't touch the screen with your fingers, which would probably deface the screen.
2. Please don't press the screen; the LCD is extremely exquisite and flimsy.
3. Please don't lay this product on unstable place.

Cleaning

1. Please clean the screen with dry and downy cloth or special LCD cleanser.
2. Please do not press hard when cleaning the screen.
3. Please do not use water or other chemical cleanser to clean the screen. The chemical may damage the LCD

Contents

Preface.....	2
Maintenance	3
Contents.....	3
Packing list.....	4
Introduction	4
Installation Dimension.....	4
Accessories introduction.....	5
Operation Instructions	7
Screen display.....	8
Zoom-in and mapping	9
Main Menu	11
Specification.....	18
Trouble-shooting.....	19

Packing List

This product offers the standard package and luxury package for option, respectively including:

Standard package:	Luxury package:	
1. D-tap to Pole-tap DC cable with lock	1. D-tap to Pole-tap DC cable with lock	6. Articulating arm trestle
2. Warranty card	2. Warranty card	7. HDMI cable with lock
3. User manual	3. User manual	8. Power adaptor
	4. S-7003U/F/D/B/I/V/C/E	9. LCD protective film
	5. Sun hood	10. Flannelette bag
		11. Carrying case

Introduction

The LCD panel and tempered glass of S-1053F adopts optical bonding process, small and thin, preventing the ash into the screen, meanwhile eliminated the air between the screen so as to display more transparent.

S-1053F adopts TFT LCD panel, with resolution 1920×1080 and wide viewing angle $H160^\circ / V160^\circ$. It supports 1 x 3G-SDI (Level A/B), 1 x HDMI input, 1 x SDI output (SDI loop through output/HDMI converted to SDI output), and supports headphone and speaker audio output.

Features:

- Unibody aluminum alloy shell
- Support HDMI converted to SDI output
- Support 2K display
- Support multiple Aspect Ratio and scan modes
- Support multiple Marker selection (Marker, Safety Area)
- Powerful audio and video analysis functions
- Support multiple functions user-defined (Source ID, function keys)
- Multiple power supply methods to meet different requirements
- USB firmware upgrade
- Camera Log conversion

Installation Dimension

The main body (in: mm)

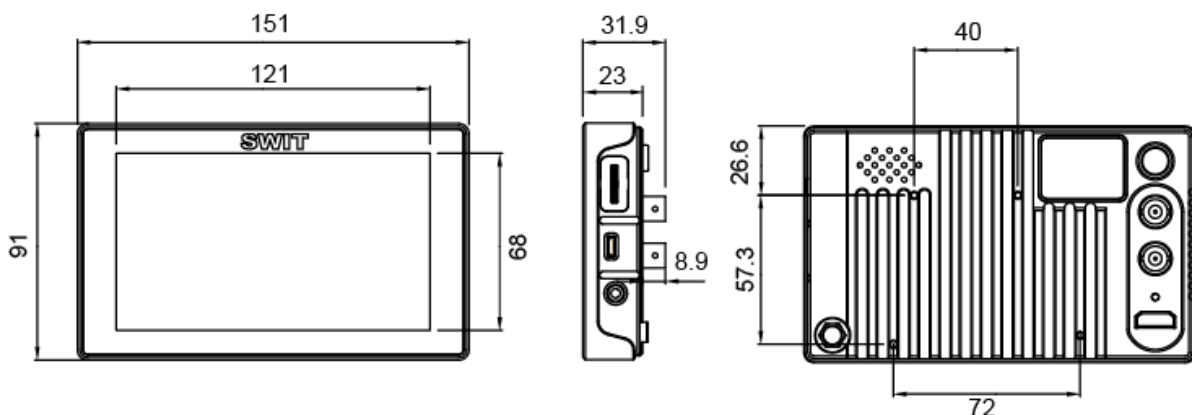

Accessories introduction

1. Sun hood

- (1) Take out the sun hood from the flannel bag, see pic1;
- (2) Push out the sun hood as pic2, unfold as pic3;
- (3) Fold the two bottom parts inward as pic3, with the internal magnets attached and fixed as pic4;
- (4) Install the sun hood on the monitor, see as pic5.

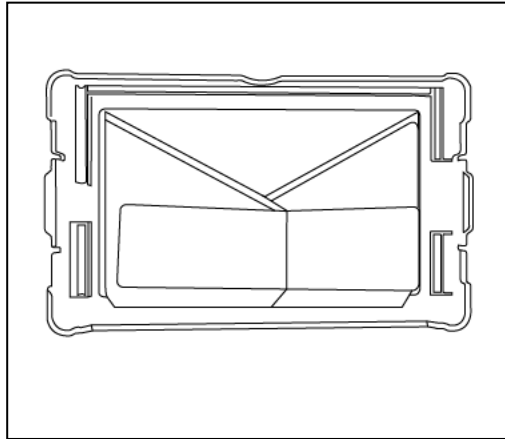

Pic.1

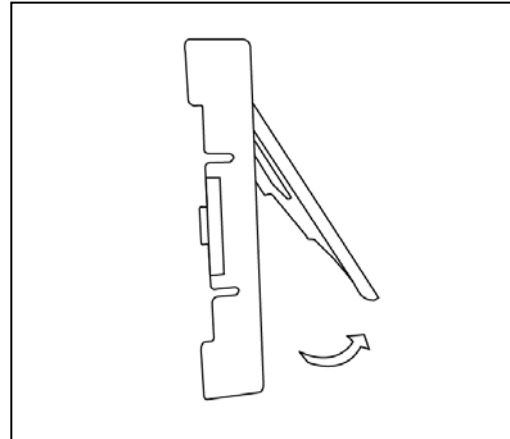

Pic. 2

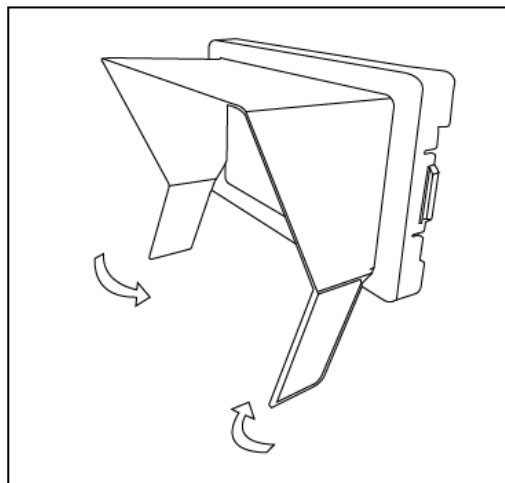

Pic. 3

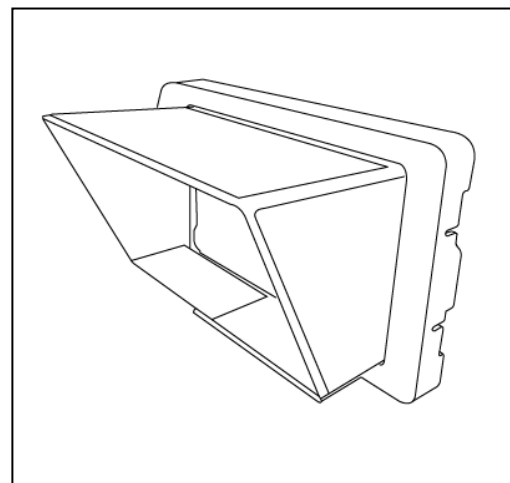

Pic. 4

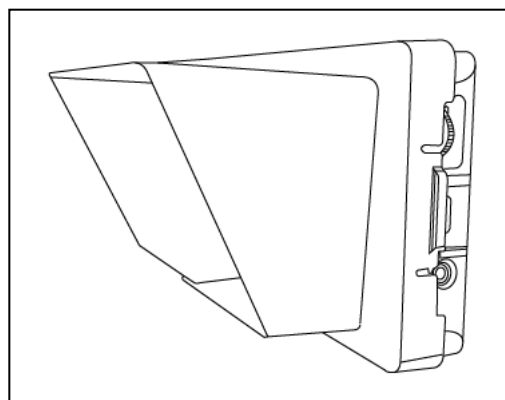

Pic. 5

2. Battery plate

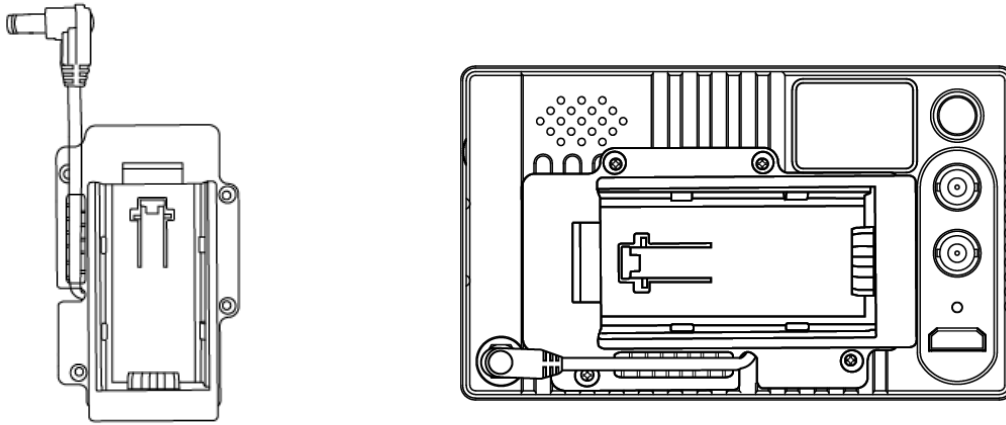

Install the battery plate on the back panel of the monitor as shown above, fix with four screws, then insert the power connector with lock to the rear housing power port, and twist the latch portion clockwise to the end. Mounting the battery to the plate can power the monitor.

3. Arm Trestle

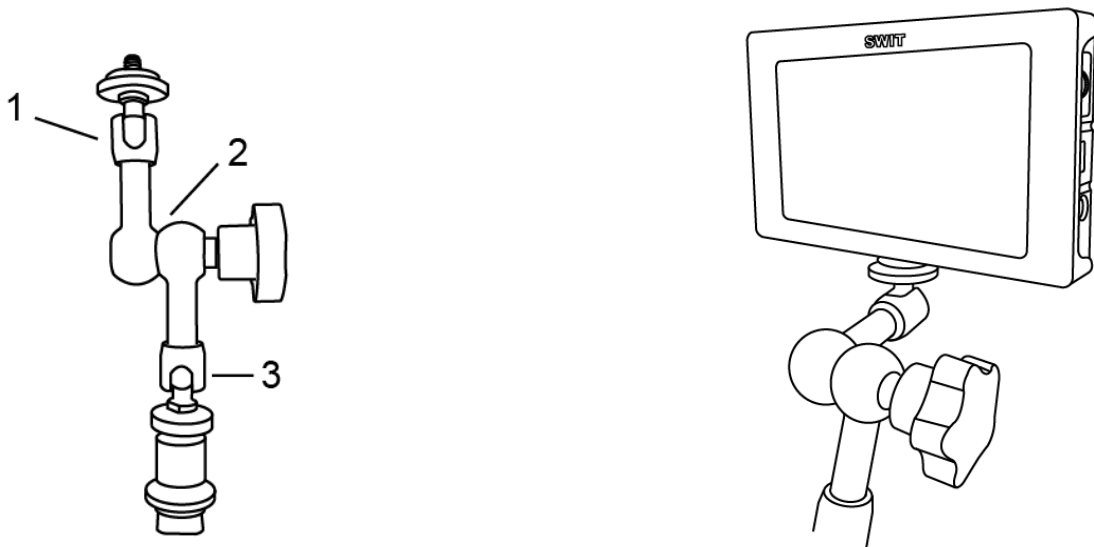

As shown in the picture above which marked with 1, 2, 3 of the arm trestle can be 360° rotated. User can rotate to any position according to their needs.

There is a 1/4 thread mounting holes on each top and bottom of the monitor to connect the monitor and arm trestle together.

Operation Instructions

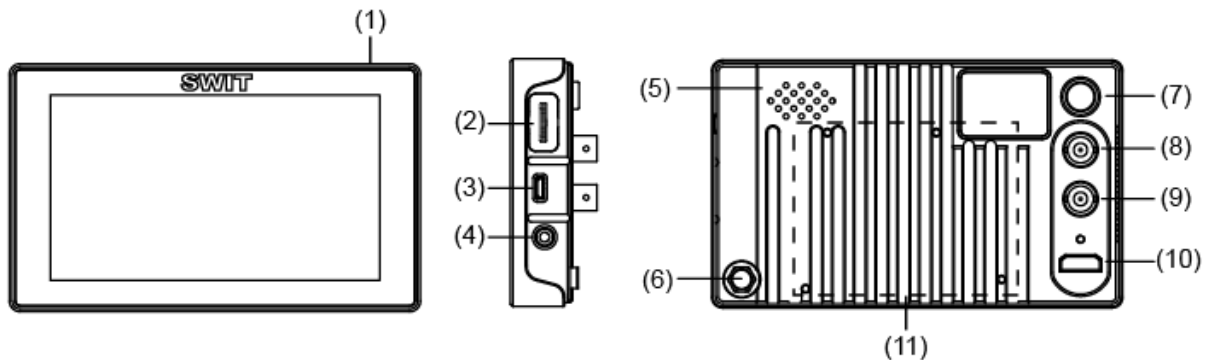

(1) User definable function keys (F1~F3)

User can set F1~F3 keys to corresponding function for quick operation according to their needs. For example: User can set F1 to “Focus Assistant”, and press F1 to directly switch the focus assistant parameter, the sequence is “Red→Blue→Off”.

Quick function keys support multi definition, for details please refer to “4.Function key settings” in the “MENU” section.

When user press function keys more than 3 seconds, it will pop-up a function definable menu, user can rotate knob or press this function key to select required functions, and press the knob to confirm the selection. If no operation exceeds 3 seconds, the monitor will automatically save the selection and Exit.

When open the main menu, user can press F3 to directly exit the menu.

(2) Main menu settings

When no menu is opened, user can directly press the knob, and open the main menu on the left top of the screen;

Rotate the knob, select corresponding submenu; the corresponding item is highlighted in yellow;

Press the knob, enter the submenu;

Rotate the knob to select items; the corresponding item is highlighted in yellow;

Press the knob, the parameter of the item is highlighted in yellow;

Rotate the knob to select the parameter and press to save the settings.

- (3) Micro USB port: Connect external storage device, for firmware upgrades.
- (4) PHONE: 3.5mm headphone jack, can monitor SDI, HDMI embedded audio.
- (5) SPEAKER: Monitor HDMI.SDI embedded audio (connecting 3.5mm audio output, the speaker is off).
- (6) DC IN: Round head DC power supply interface (Outer: Negative, Inner: Positive)
- (7) POWER: Power on/off
- (8) SDI-OUT: SDI output
 - Under SDI, loop out SDI-IN input signal;
 - Under HDMI, HDMI converted to SDI output.
- Remark: when the current input source is HDMI, the SDI-OUT will not support SD.
- (9) SDI-IN: 3G/HD/SD SDI signal input, standard BNC interface.
- (10) HDMI-IN: HDMI signal input, HDMI-A interface.
- (11) Battery plate mounting area

• Screen display

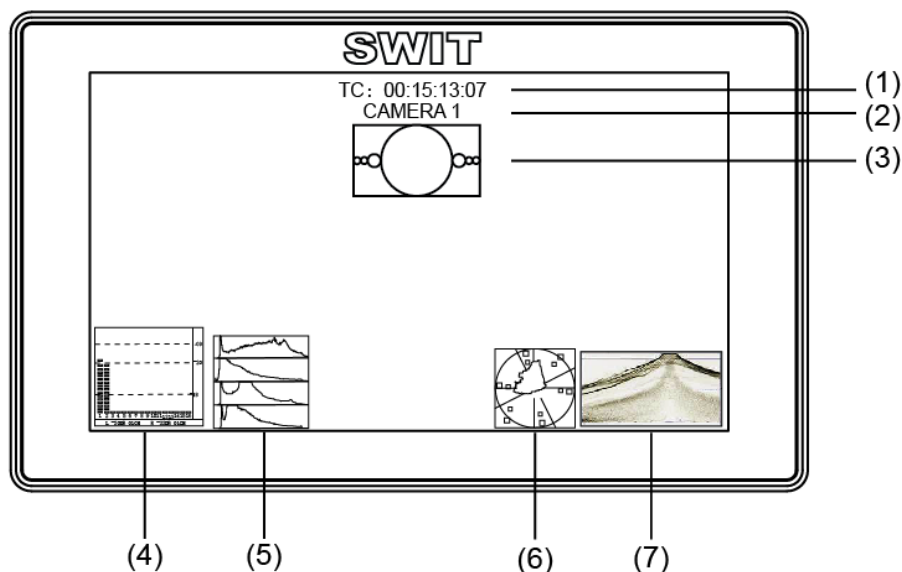

(1). Timecode (SDI)

Under SDI input, it can display Timecode. If no Timecode information is detected, it will be displayed as "TC: UNLOCKED".

User can set function keys F1~F3 as "Timecode" to turn on or off this function

(2). UMD

Display the source title. Set up the UMD under 'UMD' submenu.

(3). AFD (SDI)

User can set function keys F1~F3 as "AFD" to turn on or off this function. If no relevant information is detected, it will be displayed as "AFD: UNLOCKED".

(4). Audio

Monitor the audio information. User can set function Keys F1~F3 as "Audio" to turn on or off this function

The relevant parameters like position, audio channels and blending, etc can be changed under "Audio" submenu.

(5). Histogram

User can set function Keys F1~F3 as "Histogram" to turn on or off this function.

(6). Vector

User can set function Keys F1~F3 or GPI pins as "Vector" to turn on or off this function.

The relevant parameters like Vector position, Vector color and Vector blending, etc. can be changed under "Vector" submenu.

(7). Waveform

User can set function Keys F1~F3 or GPI pins as "Waveform" to turn on or off this function.

The relevant parameters like WFM position, WFM color and WFM blending, etc can be changed under "Waveform" submenu

• Zoom-in and mapping

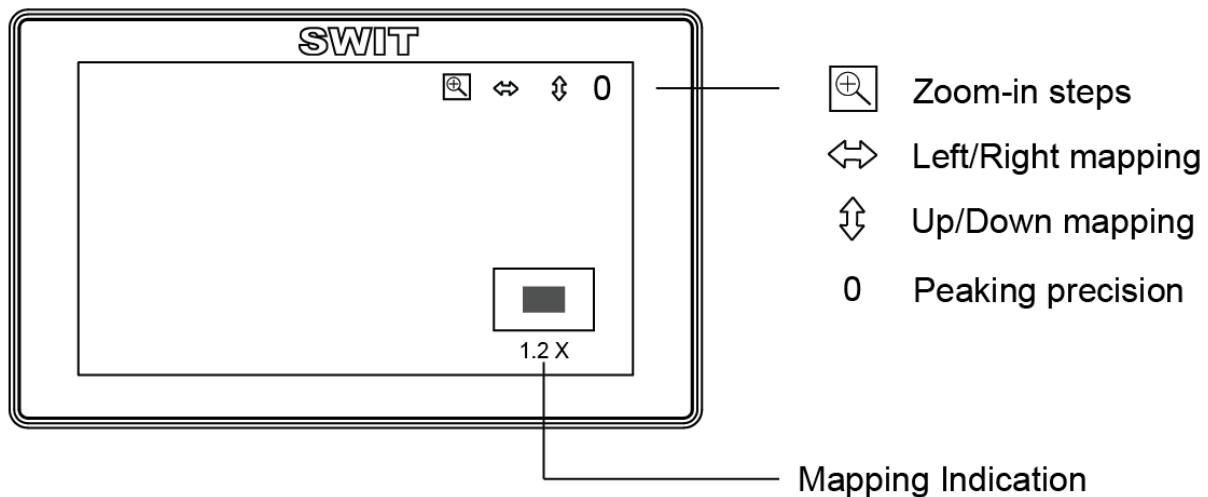

Set “Zoom-in” to function keys, and enable zoom-in mode, the OSD displays as above.

1、 Zoom-in steps operation

Scroll the Menu key up and down, to quick adjust zoom-in steps among: 1.2x, 1.5x, 1.8x, 2.0x, 2.4x, 2.6x, 2.8x and 3.0x. The zoom-in indication window is displayed on bottom right of the screen.

2、 Left and Right mapping

Press Menu key, the ⇔ button is highlighted. Scroll the Menu key up and down to move the video left and right.

3、 video left and right.

Press Menu key again, the ⇕ button is highlighted. Scroll the Menu key up and down to move the video up and down.

4、 Peaking precision adjust

Press Menu key again, the peaking precision number is highlighted. S croll the Menu key up and down to adjust the peaking focus assist precision from 0-9.

5、 Mapping indication window

Under zoom-in mode, the mapping indication window is displayed on bottom right of the screen, and indicates the zoom-in rate, up/down/left/right position.

Introduction of audio and video functions

◆ 16-ch embedded audio meters

Under 3G/HD/SD SDI, it displays 16 channels embedded audio meters. Under HDMI, it displays 2 channels embedded audio meters. The audio meter is green, and will turn yellow when audio exceeds -20dB, and turn red when audio exceeds -9dB.

◆ Audio alarm

If the embedded audio value is too low or no embedded audio, it will display “MUTE” or “UNLOCKED” in the audio bar.

◆ Time code (SDI)

Under SDI input, it can display the SMPTE time code (VITC1, VITC2 or LTC) on the top of the screen, which is used extensively for synchronization, and for logging and identifying material in recorded media. If no Time code information is detected, it will be displayed as “UNLOCKED”.

◆ Waveform (Y, Cb, Cr, R,G ,B)

Under SDI and HDMI input, totally 6 kinds of waveforms which are Y, Cb, Cr, R, G and B can be selected so as to check the brightness and chroma distribution.

◆ **Vector**

The displayed vector scope pattern is available under both SDI and HDMI, represents saturation as distance from the center of the circle, and hue as the angle, in standard position, around it.

◆ **Histogram (R.G.B)**

The histogram is a bar graph that shows the distribution of luminance values in the picture. There're R, G, B histograms that individually displayed simultaneously, available under both SDI and HDMI.

◆ **Internal Color Bar**

Under SDI and HDMI input, it has 100% internal color bar which helps to analyze the monitor color and adjust the display parameter.

User can set function Keys F1~F3 or GPI pins as "color bar" to turn on or off this function.

◆ **Peaking focus assist (red/blue switch)**

The Peaking focus assist function is to mark the sharpest edges of the image with red or blue color under SDI and HDMI input, for users to check if the subjects are focused.

User can set function Keys F1~F3 or GPI pins as "Focus Assist" to turn on or off this function

◆ **Zebra stripes**

Zebra Stripes are used to check if the image is over exposed or not by showing black and white lines on the monitor. It is considered over exposed when luminance value exceeds 90%.

User can set function Keys F1~F3 as "Zebra" to turn on or off this function.

◆ **Freeze Frame**

The freeze frame is to capture and display the current broadcast frame.

User can set function Keys F1~F3 as "Freeze Frame" to turn on or off this function

◆ **R/G/B/Mono**

R/G/B/Mono is to display only the blue/red/green primary signal or the luminance signal only so as to monitor the image noise.

User can set function Keys F1~F3 as "R/G/B/Mono" to turn on or off this function.

◆ **False Color**

The false color is used to aid in the setting of camera exposure. Under false color mode, there's a color chart on the bottom of screen for reference. The color from the dark to the bright will be displayed as blue, cyan, green, yellow, orange and red in a consecutive way. User can set function Keys F1~F3 as "False color" to turn on or off this function.

◆ **AFD (SDI)**

It is the abbreviation of active format description. AFD is to display the SDI embedded AFD information graphically on the screen.

◆ **H/V Delay (SDI)**

Under SDI input, H/V Delay can be used to display line/field blanking signal, and to observe the horizontal and vertical synchronous signal.

◆ **Image flip**

Horizontal, vertical, horizontal and vertical two-way image flip function.

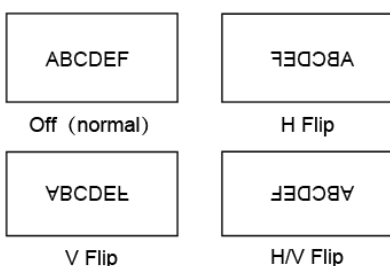

Main menu

S-1053F has OSD to adjust the parameters and settings, for example: Picture, color temp., function keys, etc.

1. Press “MENU” button, the main menu will popup from the left top of the screen. The selected main menu highlights in yellow.

Main Menu	Status
Exit&Status	HDMI XXX
Picture	User Profile XX
Color Temp	Color Temp XXXX
Function Key	Scan Mode XXX
GPI	Freeze Frame XX
UMD	Odd/Even Frame XX
Marker	F1 XX
Audio	F2 XX
Vector	F3 XX
Waveform	F4 XX
Display	F5 XX
System	System Version XX
Color Measurement	
OSD	
Key Inhibit	

2. Revolve “MENU” to select submenu, the selected submenu highlights in yellow, press “MENU” to apply and enter into the selected submenu’s items.

3. Revolve “MENU” to select the item which needed to adjust, press “MENU”, the selected item and its parameters will be highlighted in yellow.

Main Menu	Marker
Exit&Status	Exit
Picture	Marker < XXX >
Color Temp	Marker Select < 15:9 >
Function Key	Safety Area < XXX >
GPI	Fit Marker < XX >
UMD	Center Marker < XX >
Marker	Marker Color < XX >
Audio	Marker Outside < XX >
Vector	
Waveform	
Display	
System	
Color Measurement	
OSD	
Key Inhibit	

4. Revolve “MENU” to change the selected item’s parameter, press “MENU” to apply and save the settings.

5. Revolve “MENU” to select “Exit”, press “MENU” to quit submenu. Select “Exit & Status” under the Main Menu and press to quit Main Menu.

Notice:

- * The items in gray can not be set up.
- * If there is no operation under the setted time, the menu will automatically save settings and quit.
- * If the key inhabit function is turned on, except key inhibit function, all other items are in grey. Please turn off the key inhibit function to adjust the items.

Submenu introduction (the default values are marked with underline)

1. Exit & Status

Displays the current status, the details are as down below:

Exit&Status	—	HDMI ^{*1}	1080p@50Hz
	—	User Profile	Factory
	—	Color Temp	6500K
	—	Scan Mode	Normal
	—	Freeze Frame	Off
	—	Odd/Even Frame	Off
	—	F1 ^{*2}	Source
	—	F2	H/V Delay
	—	F3	Zebra
	—	F4	Mute
	—	F5	Marker
	—	System Version	VXXX-XX

*1 Display the current video signal and format

*2 Display the current function keys setup

2. Picture

To adjust picture parameters

Picture	—	Exit	
	—	Contrast	0-100, <u>50</u>
	—	Brightness	0-100, <u>50</u>
	—	Saturation	0-100, <u>50</u>
	—	Sharpness	0-100, <u>50</u>
	—	Hue	0-100, <u>50</u>
	—	Backlight	0-100, <u>50</u>

3. Color Temp

To select different color temperature or setup user-defined color parameters

Color Temp	—	Exit	
	—	Gamma	2.2、 <u>2.4</u> 、2.6
	—	Color Temp	<u>6500K</u> 、3200K、5600K、9300K、User
	—	Red Gain	0-255, 128
	—	Green Gain	0-255, 128
	—	Blue Gain	0-255, 128
	—	Red Bias	0-255, 128
	—	Green Bias	0-255, 128
	—	Blue Bias	0-255, 128

* Only “Color Temp” is set to “User”, the Red/Blue/Green Gain or Red/Blue/Green Bias can be adjusted.

4. Function key

To define the F1~F3 function keys

Function Key	—	Exit	
	—	F1 ^{*1}	<u>Source</u>
	—	F2	<u>Waveform</u>
	—	F3	<u>Display</u>
	—	F4	Mute
	—	F5	Marker

*1 Function keys F1-F3 can be setted as the down below functions:

source, Waveform, Display, Color Temp, Time Code, Zebra, Vector, Audio Bar, Histogram, False Color, AFD, H/V Delay, R/G/B/Mono, Marker, Color Bar, UMD, Audio Alarm, Max backlight, Focus Assist, Aspect Ratio, Scan Mode, Zoom Mode, Mute, Freeze Frame, Flip Mode.

For example: Set F3 to "R/G/B/Mono" under "Function key" submenu. User can press F3 on the front panel to adjust the parameters of "R/G/B/Mono", and the "R/G/B/Mono" will change and follow the sequence: Blue Only → Red Only → Green Only → Mono → Off.

5. UMD

UMD	Exit	
	RS485 Address	1
	Position	<u>T</u> op, Bottom
	Display Type	Source ID
	Baud Rate	38400
	Parity	Even
	Serial Port	RS485
	Source ID	<u>C</u> AMERA 1

Set "UMD":

(1) Select "Source ID"

(2) The underline flashes as a reminder on the bottom of the first letter. Revolve "MENU" to select the letters; the letter will follow the sequence of the down below if clockwise revolved:

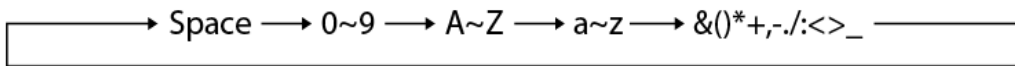

(3) Press "MENU" to save the current settings letter and then start to set the next letter.

(4) Repeat step (2) and step (3), max 8 letters are supported.

(5) Press "Exit" to quit and save the settings.

6. Marker

Marker	Exit	
	Marker	<u>O</u> ff, On
	Marker Select	Off, 4:3, 13:9, 14:9, 15:9, 16:9, <u>1.85:1</u> , 2.35:1
	Safety Area	Off, 80%, 85%, <u>90%</u> , 93%, 95%
	Fit Marker*1	<u>O</u> ff, On
	Center Marker	Off, <u>O</u> n
	Marker Color	<u>W</u> hite, Red, Green, Blue, Black, Gray
	Marker Outside	Off, <u>G</u> ray, Black

*1 When "Fit Marker" is "Off", the size of safety area is benchmarked against the actual display screen, accounting for 80% ~ 95% of actual display screen. When "Fit Marker" is "On", the size of safety area is benchmarked against the area inside the scales marker, accounting for 80% ~ 95% of the area inside the scales marker.

Example:

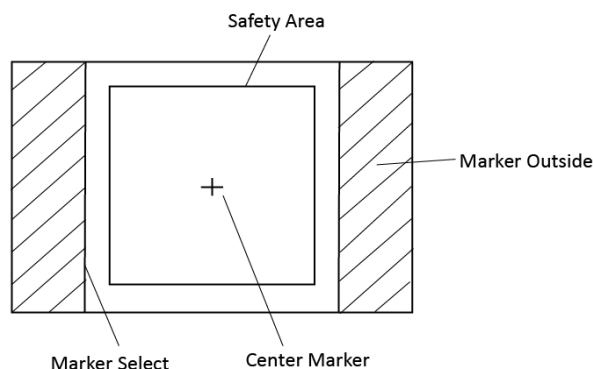

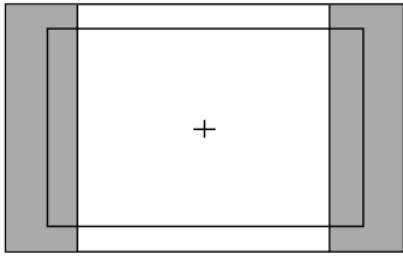

Aspect ratio: 4:3
 Safety Area: 85%
 Center Marker: On
 Fit Marker: Off

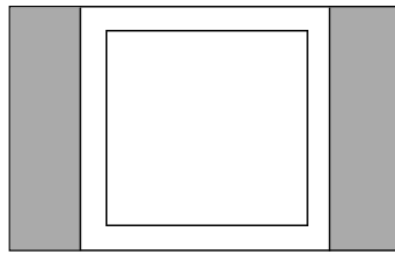

Aspect ratio: 4:3
 Safety Area: 85%
 Center Marker: Off
 Fit Marker: On

7. Audio

Audio	Exit	
	Audio Bar	<u>Off</u> , On
	Bar Frame*1	Off, <u>On</u>
	Bar Position	<u>Top Right</u> , Bottom Left, Bottom Right, Top Left
	Bar Blending	<u>Low</u> , Off, High
	Audio Alarm*2	Off, On
	Select Channel*3	<u>Channel 1-2</u> , 1-8, 1-16
	Left Channel*4	CH1-CH16, <u>CH1</u>
	Right Channel	CH1-CH16, <u>CH2</u>
	Volume	0-31, <u>15</u>

*1 When "Bar Frame" is set to "Off", only the audio meter will be displayed.
 When "Bar Frame" is set to "On", frame and real-time audio value will be displayed.

*2 Select Channel
 Under HDMI signal, channel1-2 can be selected.
 Under SDI signal, channel 1-2, 1-8 and 1-16 can be selected.

*3 When "Audio Alarm" is set to "On", if no embedded audio is detected, the audio bar will display "UNLOCKED". If the audio value is too low, the audio bar will display "MUTE"

*4 Audio channels can be selected to output according to the requirements.
 When the current "Select Channel" is set to "Channel1-2", the left channel and right channel output can be selected from Channel1 or channel2.

When the current "Select Channel" is set to "Channel1-8", the left channel and right channel output can be selected from Channel1 to channel8.

When the current "Select Channel" is set to "Channel1-16", the left channel and right channel output can be selected from Channel1 to channel 16.

In audio bar, the left channel information will be in green, and the right channel information will be in red.

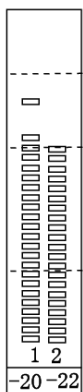

Channel1~2

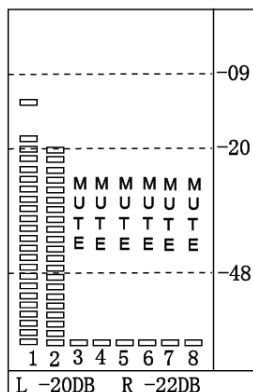

Channel1~8

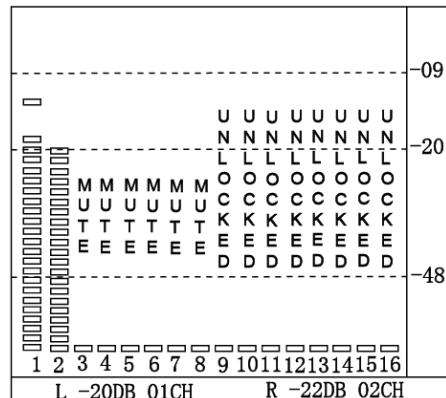

Channel1~16

8. Vector

Vector	Exit	
	Vector	<u>Off</u> , On
	Vector Position	<u>Bottom Right</u> , Center, Top Left, Top Right, Bottom Left
	Vector Blending	Off, <u>Low</u> , High
	Vector Color	Color, White, Green, <u>False Color</u>
	Histogram	<u>Off</u> , On
	Histogram Blending	<u>Low</u> , Off, High

9. Waveform

Waveform	Exit	
	Waveform	<u>Off</u> , On
	WFM Type	<u>Y</u> , Cb, Cr, R, G, B
	WFM Position	<u>Bottom Left</u> , Bottom Right, Center, Top Left, Top Right
	WFM Blending	<u>Low</u> , High, Off
	WFM Color	<u>White</u> , Green, False Color
	WFM Single Line	<u>Off</u> , On
	WFM Line Count *1	0-1079, <u>0</u>

*1: Only the "WFM Single Line" is set to "ON", the "WFM Line Count" can be adjusted.
 "WFM Single Line" is to display the selected line waveform of "WFM Line Count"



WFM Single Line: Off

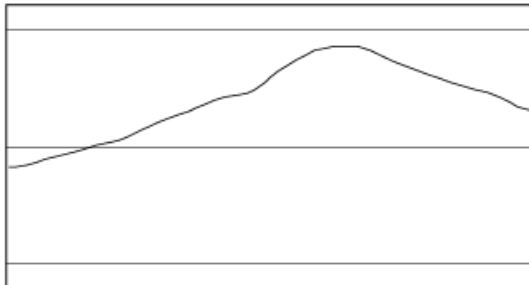

WFM Single Line: On

10. Display

Display	Exit	
	Waveform	<u>Off</u> , On
	Audio Bar	<u>Off</u> , On
	Vector	<u>Off</u> , On
	Zebra	<u>Off</u> , On
	Focus Assist	<u>Off</u> , Blue, Red
	Time Code	<u>Off</u> , On
	Histogram	<u>Off</u> , On
	False Color	<u>Off</u> , On
	AFD	<u>Off</u> , On
	H/V Delay	<u>Off</u> , On
	R/G/B/Mono	<u>Off</u> , Blue Only, Red Only, Green Only, Mono
	Color Bar	<u>Off</u> , On
	Marker	<u>Off</u> , On
	UMD	<u>Off</u> , On

11. System

System	Exit	
	Aspect Ratio	<u>16:9</u> 、4:3、Auto
	Scan Mode	<u>Normal</u> 、OverScan、Native
	Zoom Mode	<u>Off</u> 、Zoom1、Zoom2
	Odd/Even Frame	Off
	Color Space* ¹	<u>Auto</u> 、RGB(4:4:4)、YCbCr(4:4:4)、YCbCr(4:2:2)
	Freeze Frame	<u>Off</u> 、On
	Flip Mode	<u>Off</u> 、H Flip、V Flip、H/V Flip
	Recall Profile	<u>Factory</u> 、User1、User2、User3
	Save Profile	<u>User1</u> 、User2、User3
	Source Scan* ²	<u>On</u> 、Off
	Logo* ³	<u>On</u> 、Off
	Green Mode	Black Backlight
	Idle Duration	2Hours
	Update Driver* ⁴	<u>No</u> 、Yse
	Update Kernel* ⁵	<u>No</u> 、Yes

*1 Color space

The default color space parameter is automatic. It will automatically display based on the input signal recognized color space. If the signal can not recognize the correct color space, user should manually adjust the color space to correctly display.

*2 Source Scan

When set to "Yes", after turn on the monitor, the signal will be inspected and follow the sequence of "SDI→HDMI→SDI"

For example: if channel is selected to SDI, SDI-IN has no input, and HDMI has input. When turn on the monitor, after automatic inspection, SDI has no recognized signal, and HDMI has recognized signal, then the input signal will be HDMI.

When set to "No", update model will not be supported.

*3 Logo

When powered on, the screen will display SWIT logo.

*4.*5 Update Driver/ Kernel

(1) Open the power supply, plug the U disk with upgrading program into the Micro USB port on the side of the monitor;

(2) Press "MENU" rotary knob, open the main menu, enter the "system" submenu, select "Driver/Kernel";

(3) Set the parameter to "Yes", and press "MENU" rotary knob to begin upgrading;

(4) While upgrading, there will be a progress bar displaying on the screen (Note: Do not power off when upgrading);

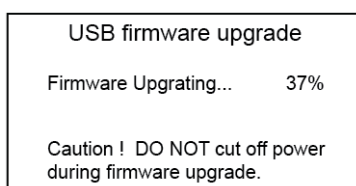

(5) After upgraded, the monitor will automatically reboot.

12. Color Measurement

Color Measurement	Exit	
	Log Mode*1	Off、J-Log1、Log-C、S-Log2、S-Log3、 C-Log、V-Log、RedlogFilm、User-Log
	1DLut	Default
	Color Measurement	Off
	Import *2	J-Log1.cube、Log-C.cube、S-Log2.cube、 S-Log3.cube、C-Log.cube、V-Log.cube、 RedLogFilm.cube、User-Log.cube
	Reset*3	J-Log1.cube、Log-C.cube、S-Log2.cube、 S-Log3.cube、C-Log.cube、V-Log.cube、 RedLogFilm.cube、User-Log.cube

*1 Camera Log conversion

When shooting with Log mode of the camera, you can select the corresponding Log conversion LUT, to convert the log mode video to standard ITU Rec.709 mode to monitor. A "User-Log" is provided for user defined LUT converting to Rec.709.

*2 Import 3DLUT cube file

The monitor pre-imported the correct 3DLUT cube files to convert camera logs to Rec. 709. And you can import your own 3DLUT cubes to "User-log.cube" space. You can also import 3DLUT cubes to camera logs space to cover them.

- (1) Copy the user cube file to USB stick, and rename the cube file to "User-Log.cube" (attention to the cap letters).
- (2) Insert USB stick to the rear panel of the monitor.
- (3) Operate Menu – Color Measurement – "Import" – "User-Log.cube" – "Yes" to import.

*3 Reset to factory cubes

For any wrong cubes imported that caused wrong display colors, you can reset the cubes to factory cubes here.

13. OSD

OSD	Exit	
	OSD Language	English、Chinese
	OSD Blending	Low、Medium、High、Off
	OSD Duration	10Sec、15Sec、30Sec、60Sec
	OSD Zoom	Off、On
	Key Led Brightness	Low
	Tally-R Brightness	High
	Tally-G Brightness	High

14. Key Inhibit

Key Inhibit	Exit	
	Key Inhibit	Off、On

When the "Key inhibit" is set to "on", there is no response when all the buttons except "MENU" is pressed, the screen will be displayed as "Key Inhibit".

User can set "Key inhibit" to off under the "Key inhibit" submenu, restore the function of all keys.

Specification

LCD Performance		
Size	5.5 inch	
Display area	120.96×68.04 mm	
Resolution	1920×RGB×1080	
Color	8 bit	
Aspect ratio	16:9 / 4:3	
Brightness	400 cd / m ²	
Contrast	1000:1	
Viewing angle	Horizontal / Vertical: 160° / 160°	
Input / Output		
Input	HDMI×1	HDMI input
	BNC×1	3G/HD/SD-SDI input
	USB×1	
Output	BNC×1	3G/HD/SD-SDI loop through output
	3.5mm×1	SDI/HDMI audio output
Video format		
HDMI	480i / 576i / 480p / 576p	
	1080i (60 / 59.94 / 50)	
	720p (60 / 59.94 / 50)	
	1080p (60 / 59.94 / 50 / 30 / 29.97 / 25 / 24 / 23.98)	
	1080psf (30 / 29.97 / 25 / 24 / 23.98)	
SDI	SMPTE-425M-A/B	1080p (60 / 59.94 / 50)
	SMPTE-274M	1080i (60 / 59.94 / 50)
		1080p (30 / 29.97 / 25 / 24 / 23.98)
	SMPTE-RP211	1080psf (30 / 29.97 / 25 / 24 / 23.98)
	SMPTE-296M	720p (60 / 59.94 / 50)
	SMPTE-125M	480i (59.94)
	ITU-R BT.656	576i (50)
SMPTE-2048-2	2048×1080p (23.98 / 24 / 25 / 29.97 / 30 / 50 / 59.94 / 60) 2048×1080i (50 / 59.94 / 60)	
General		
Input voltage	DC / battery: 6.5V~36V	
Power consumption	Regular: 7.5W Max: 12W	
Working temperature	-10°C~+50°C	
Working humidity	10%~90%	
Storage temperature	- 15°C ~ + 60°C	
Storage humidity	10%~90%	
Dimensions	151×91×32mm	
Net weight (main body)	375 g	

Trouble-shooting

symptom	Possible causes	Solution
No display	The power is not turned on	Please check if the power is connected, and then press "POWER" button to turn on the monitor
	Unstable power voltage	Reconnect to power supply
	BNC or HDMI cable loose contact or not correctly connected	Check and correctly connect the BNC or HDMI cable
	The attached battery is no power	Change battery
	Using DIY power supply but the polarity is reversed	Refer to the provided power supply, reconnect the power.
Image or color abnormal	Bad contact of BNC or HDMI cable	Change cable
	Video signal has Interference	Remove the interference source(s)
	Improper adjustment of the color parameters	Adjust the "Recall profile" to "Default" under "System" submenu
	Distortion of the image	Reset the Aspect ratio
	Set to Red/Green/Blue only or Mono	Turn the Blue only/ Red Only/ Green Only/Mono off under R/G/B/Mono submenu
	Turn on the "Focus Assist" function	Turn off the "Focus Assist" function
	Turn on the "False Color" function	Turn off the "False Color" function
	Signal can not correctly recognize color space, wrong set of HDMI color space.	Set to the correct color space mode
No audio output	Set to Mute	Turn off MUTE or revolve "MENU/ENTER" to adjust the volume
	Bad contact of signal cable	Connect to the correct input socket

SWIT®